

BI 8-Q10-VP6X2-0.2M-RS 4.4T

Inductive sensor

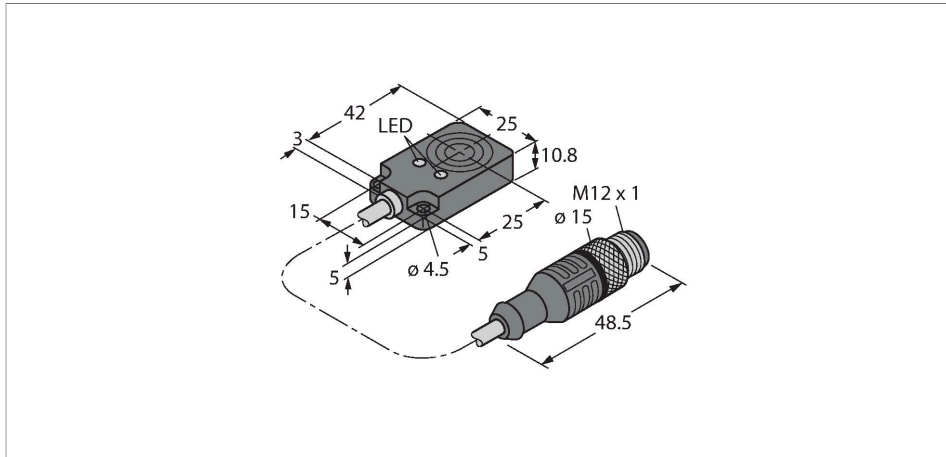

- Rectangular, height 10.8 mm
- Active face on top
- Plastic, PBT-GF30-V0
- DC 4-wire, 10...30 VDC
- Changeover contact, PNP output
- Cable with male end M12 x 1

Wiring diagram

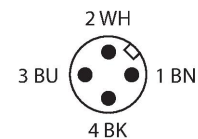
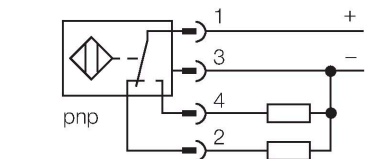

Type	BI 8-Q10-VP6X2-0.2M-RS 4.4T
Ident. no.	1662097
Rated switching distance	8 mm
Mounting conditions	Flush
Secured operating distance	≤ (0,81 x Sn) mm
Correction factors	St37 = 1; Al = 0.3; stainless steel = 0.7; Ms = 0.4
Repeat accuracy	≤ 2 % of full scale
Temperature drift	≤ ± 10 %
Hysteresis	3...15 %
Ambient temperature	-25...+70 °C
Operating voltage	10...30 VDC
Residual ripple	≤ 10 % U _{ss}
DC rated operational current	≤ 200 mA
No-load current	≤ 15 mA
Residual current	≤ 0.1 mA
Isolation test voltage	≤ 0.5 kV
Short-circuit protection	yes / Cyclic
Voltage drop at	≤ 1.8 V
Wire breakage/Reverse polarity protection	yes / Complete
Output function	4-wire, Complementary contact, PNP
Switching frequency	1 kHz
Design	Rectangular, Q10
Dimensions	42 x 25 x 10.8 mm
Housing material	Plastic, PBT-GF30-V0
Active area material	PBT-GF30-V0
Material coupling nut	metal, CuZn, nickel-plated

Functional principle

Inductive sensors detect metal objects contactless and wear-free. For this, they use a high-frequency electromagnetic AC field that interacts with the target. Inductive sensors generate this field via an RLC circuit with a ferrite coil.

Electrical connection	Cable with connector, M12 × 1
Cable quality	5.2 mm, LifYY, PVC, 0.2
Cable cross section	4 x 0.25 mm ²
Vibration resistance	55 Hz (1 mm)
Shock resistance	30 g (11 ms)
Protection class	IP67
MTTF	2283 years acc. to SN 29500 (Ed. 99) 40 °C
Power-on indication	LED,Green
Switching state	LED,Yellow

Mounting instructions/Description

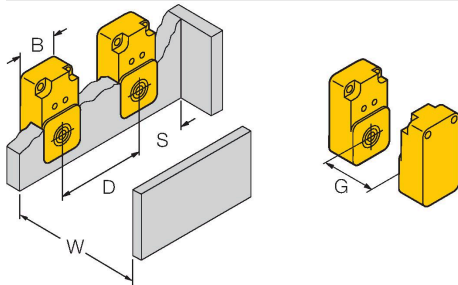

Distance D	2 x B
Distance W	3 x Sn
Distance S	1 x B
Distance G	6 x Sn
Width active area B	25 mm